

REV.	Q' TY	ECN. NO.	REASON&CONTENTS	SIGN	DATE
AO			Add Material of housing	Lizan	2016/02/24

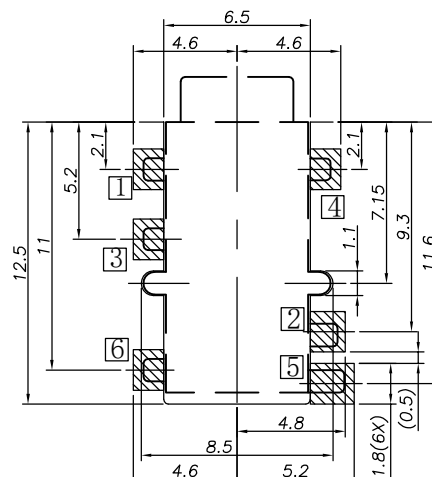
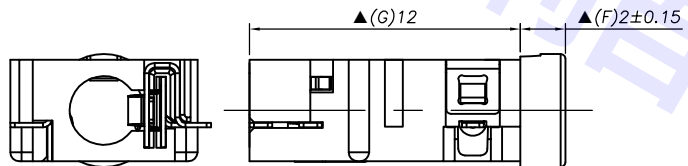
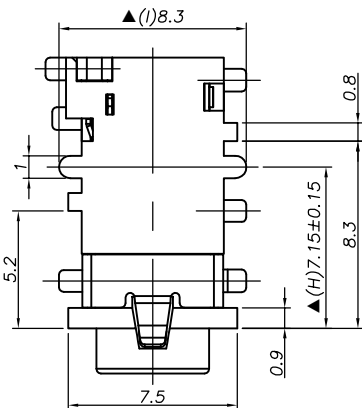
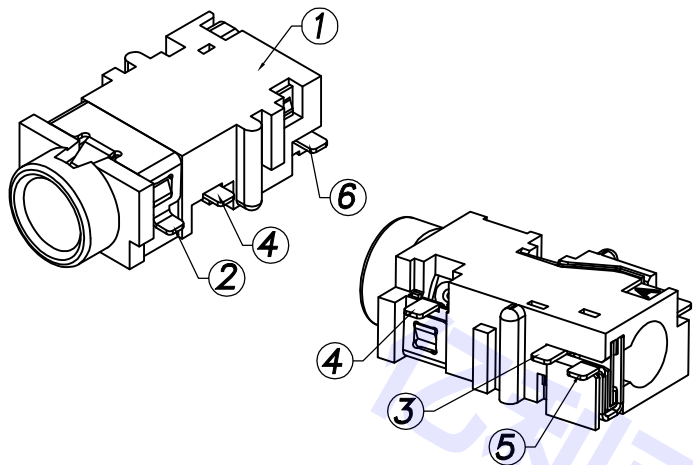

RECOMMENDED P. C. B. LAYOUT  
UNSPECIFIED TOLERANCE:  $\pm 0.05$   
(COPPER-SIDED VIEW)

Ordering information:

PJ31830-□ □ □ □ □ □ □ 1  
(1) (2) (3) (4) (5) (6) (7)

- (1): Series No.
- (2): Schematic option: I, A, B, M
- (3): Material of housing:  
9T=PA9T (Standard) 6T=PA6T
- (4): Housing color:  
0A=Black 2L=Pink (701C/0405)  
5G=Lime (577C/0406) 6A=Blue (284C/0432)
- (5): Terminal plating  
G=Gold (Au) (Standard)  
S=Silver (Ag)
- (6): Special option:  
00=No special option  
0H=HF
- (7): Packing mode:  
1=Tape reel packing

Matching Plug

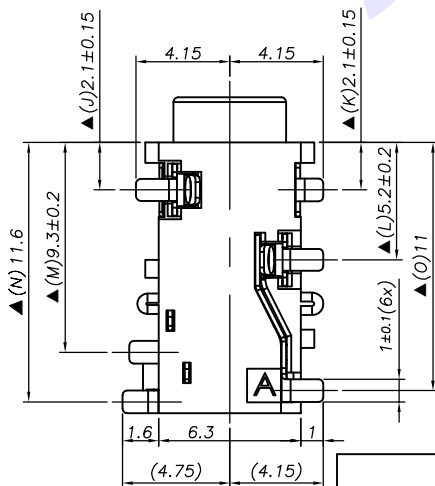
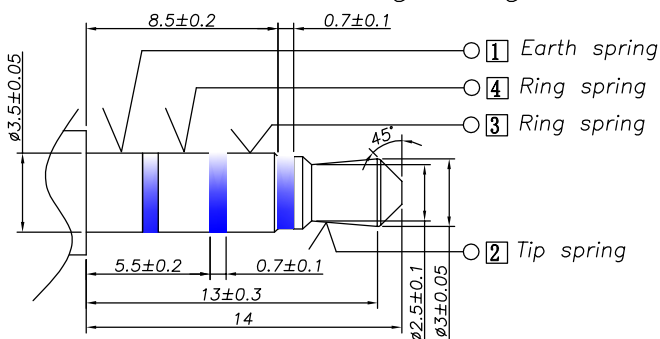

Specification:

1. Rating : DC 30V 0.5A;
  2. Contact resistance:  $\leq 30m\Omega$ ;  
After test:  $\leq 50m\Omega$
  3. Insulation resistance:  $\geq 100M\Omega$  (500VDC);  
After test:  $\geq 50M\Omega$
  4. Withstanding voltage: 500VAC;
  5. Insertion and extraction force: 3N~30N;
  6. life test: 5000cycles min;
  7. Operation temperature range:  $-20^{\circ}C \sim 70^{\circ}C$
  8. Preservative temperature range:  $-25^{\circ}C \sim 80^{\circ}C$
- Sign "▲" is importance dimension.

Model No.	PJ31830-I	PJ31830-A	PJ31830-B	PJ31830-M
Schematic				

NO.	DESCRIPTION	Q' TY	MATERIAL	REMARK
⑥	Shunt terminal ⑥	1	Phosphor bronze t0.2	Ag/G. f
⑤	Shunt terminal ⑤	1	Phosphor bronze t0.2	Ag/G. f
④	Ring spring ③ ④	1	Phosphor bronze t0.2	Ag/G. f
③	Tip spring ②	1	Phosphor bronze t0.2	Ag/G. f
②	Earth spring ①	1	Phosphor bronze t0.2	Ag/G. f
①	Housing	1	High Temp. Thermoplastic	—

THIS DOCUMENT IS THE SOLE PROPERTY OF Bsun ELECTRONICS CO., LTD. AND SHOULD NOT BE USED IN WHOLE OR IN PART WITHOUT PRIOR WRITTEN PERMISSION.

UNIT: MM

TOLERANCE		TYPE: ø3.5 PHONE JACK	MODEL NO: PJ31830-_____1	DRAWING TYPE: CUSTOMER DRAWING			
DIMENSIONS	ANGLES			DRAWING NO: BSCR-0000-0300	SCALE	VER.	PAGE
.X ±0.38	X ±5°				N/A	AO	1/1
.XX ±0.30	.X ±3°						
.XXX ±0.15	.XX ±2°						

DESIGNER BY: \_\_\_\_\_

CHECK BY: \_\_\_\_\_

APPROVED BY: \_\_\_\_\_

**GDEL** 深圳市亿利百斯特电子有限公司