

REV.	QTY	ECN. NO.	REASON&CONTENTS	SIGN	DATE
△1	X1		Change D/C.	P. J	2016. 08. 30
△2	X1		Add to Mylar.	P. J	2016. 09. 08
△3			Modify Tolerance	Daniel	2019. 12. 31

- Specification:
- Rating : DC 30V 0.5A.
  - Contact resistance:  $\leq 50m\Omega$ .  
After life test:  $\leq 100m\Omega$ .
  - Insulation resistance:  $\geq 100M\Omega$  (500VDC).  
After life test:  $\geq 50M\Omega$ .
  - Withstand voltage: 500VAC.
  - Insertion force: 0.5~2Kg.  
Withdrawal force: 0.5~2Kg
  - life test: 5000cycles min.
  - Operation temperature range:  $-20^{\circ}C \sim 70^{\circ}C$ .
  - Preservative temperature range:  $-40^{\circ}C \sim 85^{\circ}C$ .

- Ordering information:  
PJ3276B- Y 10 0A □ □ □ 1  
(1) (2) (3) (4) (5) (6) (7)
- Series No.
  - Schematic option: Y
  - Material of housing:  
10=PA10T
  - Housing color:  
0A=Black (Standard)
  - Terminal plating  
G=Gold Flash on contact area  
3=Au 30u" on contact area
  - Special option:  
00=No special option  
M0=With Mylar
  - Packing mode:  
1=Tape&Reel packing

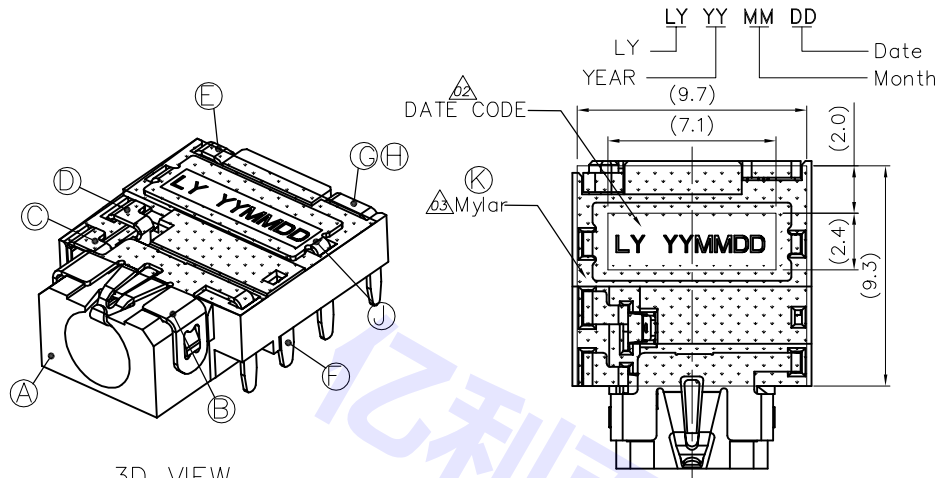

3D VIEW

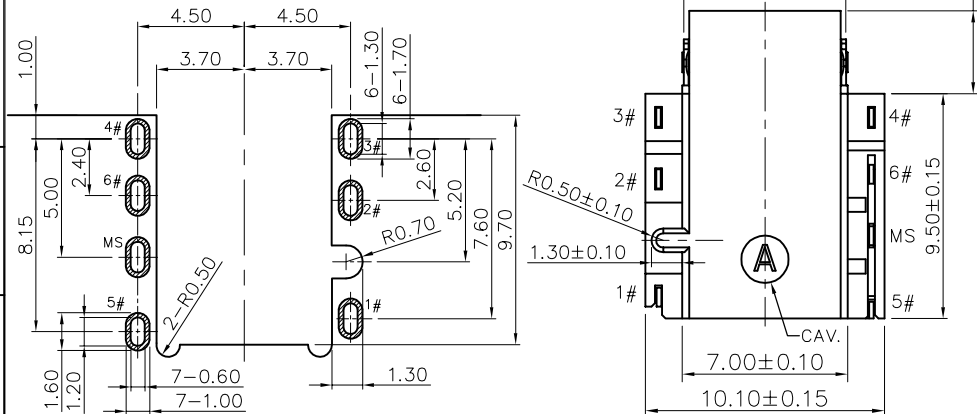
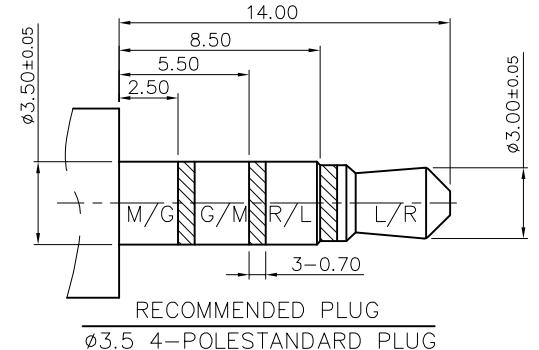
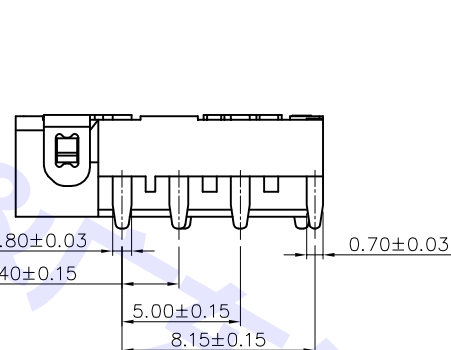
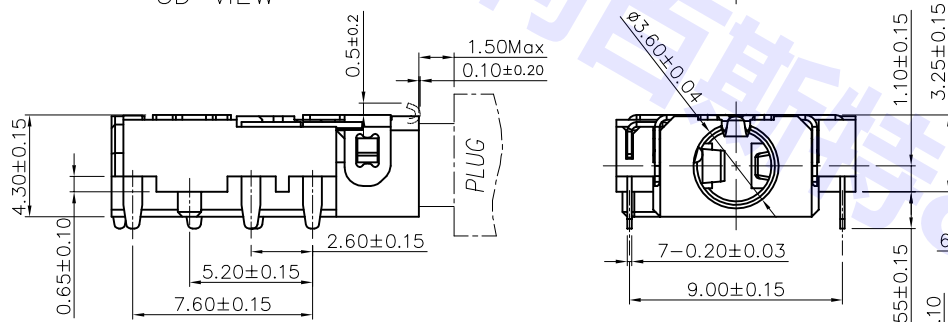

RECOMMAND P.C.B LAYOUT  
TOLERANCE: ±0.05

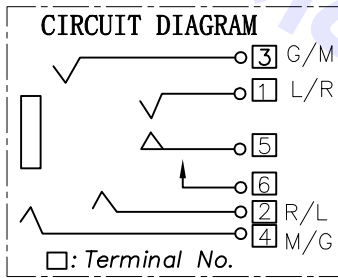

K	Mylar	1pcs		T=0.15mm
J	Shell	MS 1pcs	SUS304-3/4H t=0.20	All over 40u" Ni
H	Separator	1pcs	PA10T (R630NH)+30%GF	BLACK
G	Transfer	5 1pcs	C5210R-EH t=0.20	Au on contact area Gold flash on solder area All over 40u" Ni min
F	MAKE terminal	6 1pcs	C5210R-EH t=0.20	
E	TIP Spring	1 1pcs	C5210R-EH t=0.20	
D	Ring B	2 1set	C5191R-H t=0.20	
C	Ring A	3 1set	C5191R-H t=0.20	
B	Earth	4 1pcs	C5191R-H t=0.20	
A	Housing	1pcs	PA10T (R630NH)+30%GF	BLACK
NO.	DESCRIPTION	QTY	MATERIAL	REMARK

THIS DOCUMENT IS THE SOLE PROPERTY OF Bsun ELECTRONICS CO., LTD. AND SHOULD NOT BE USED IN WHOLE OR IN PART WITHOUT PRIOR WRITTEN PERMISSION.	UNIT:MM	TOLERANCE		TYPE:	MODEL NO:	DRAWING TYPE:
		DIMENSIONS	ANGLES	ø3.5 PHONE JACK	PJ3276B-Y100A__1	CUSTOMER DRAWING
		.X ±0.50	X ±5°			
	.XX ±0.30	.X ±3°			DRAWING No:	SCALE: VER. : PAGE:
	.XXX ±0.15	.XX ±2°			BSCR-0000-0328	1:1 04 1/1
DESIGNER BY:						<b>GDEL</b> 深圳市亿利百斯特电子有限公司
CHECK BY:						
APPROVED BY:						