

# 承認書

APPROVE SHEET



敬請承認如下之形式規格書：

客戶名稱

CUSTOMER: \_\_\_\_\_

貴公司製品名

本公司製品名：

撥动开关

CUSTOMER PN: \_\_\_\_\_ PRODUCT PN: \_\_\_\_\_

貴公司規格

本公司規格：

EL-MSK56A

APPROVAL DAT: \_\_\_\_\_ PRODUCT CODE: \_\_\_\_\_

客戶料號：

本公司規格書編號：

CUSTOMER NO.: \_\_\_\_\_ PRODUCT DRAWING NO.: \_\_\_\_\_

新品承認

NEW APPROVE

規格變更再承認

CHANGE CODE APPROVE

AGAIN

材料變更再承認

CHANGE MATERIAL APPROVE

AGAIN

APPROVAL

批准

DATE:

CHECK

審查

DATE:

DESIGN

設計

DATE:

貴公司承認欄

APPROVAL SIGNATURES

請於\_\_\_\_年\_\_\_\_月\_\_\_\_日前承認返回

日期 DATE: \_\_\_\_\_

PLEASE RETURN TO ADMIT XUNIANRURI

**深圳市亿利百斯特电子有限公司**

ShenZhen ElyBest Electronics Co., Ltd

付文鹏 (Vincent Fu)

Tel : 0755-28213003

Fax: 0755-85215085

Mob: 18923844556

Email : vincent@elybest.com

Add : 深圳市龙岗区平湖街道世之鼎产业园B栋220

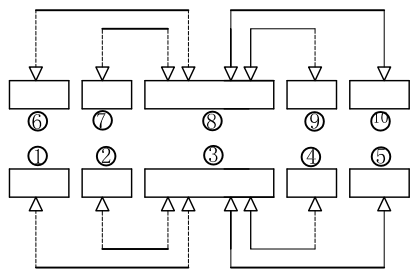
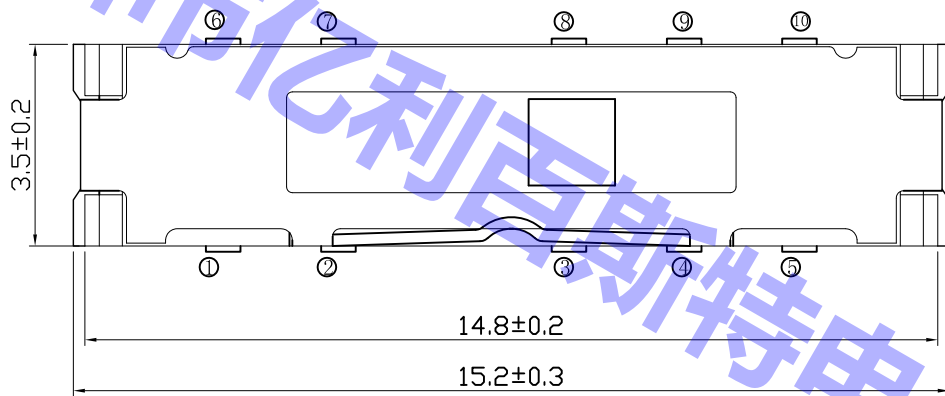
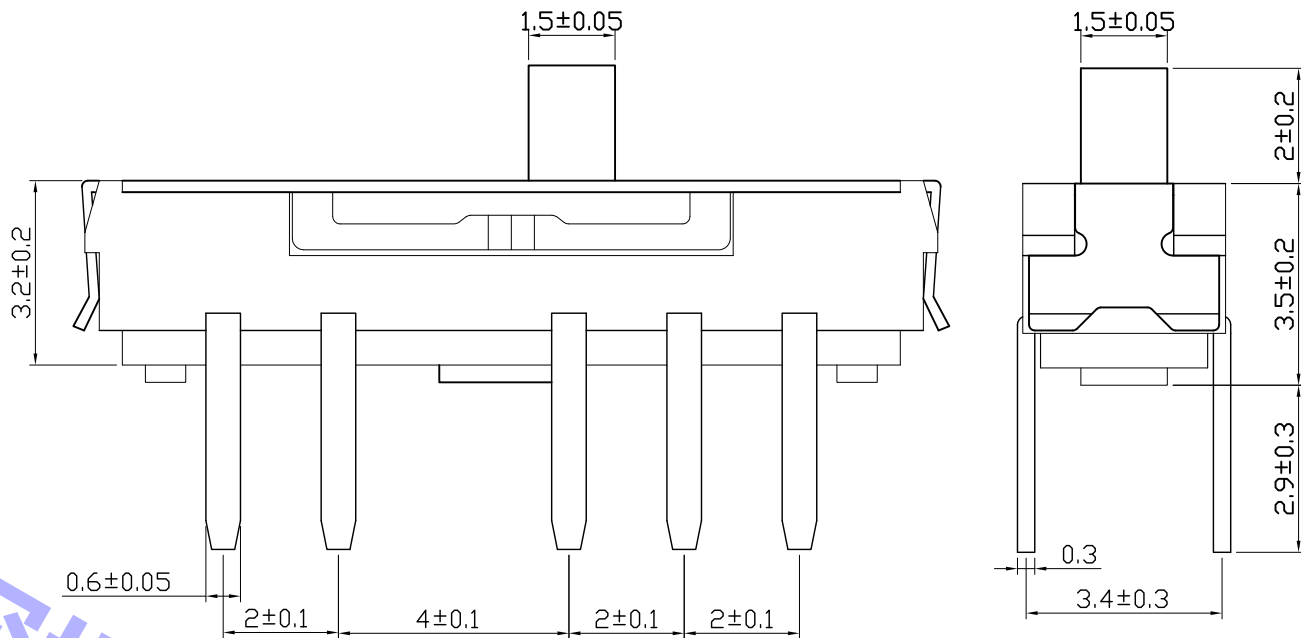

电路图 (CIRCUIT DIAGRAM)

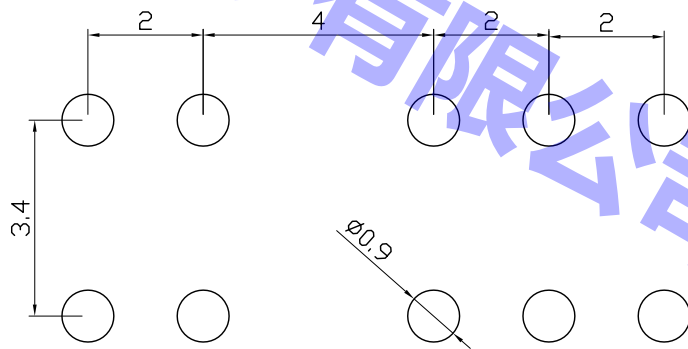

安装图 (PCB LAYOUT PLAN)

型号

推柄长度

底座颜色

EL-MSK56A

G2.0

黑

深圳市亿利百斯特电子有限公司  
ShenZhen ElyBest Electronics Co., Ltd

备注

比例1:1

制定

核对

审批

日期

尺寸单位

此数据仅供参考，实际以样品为准

mm

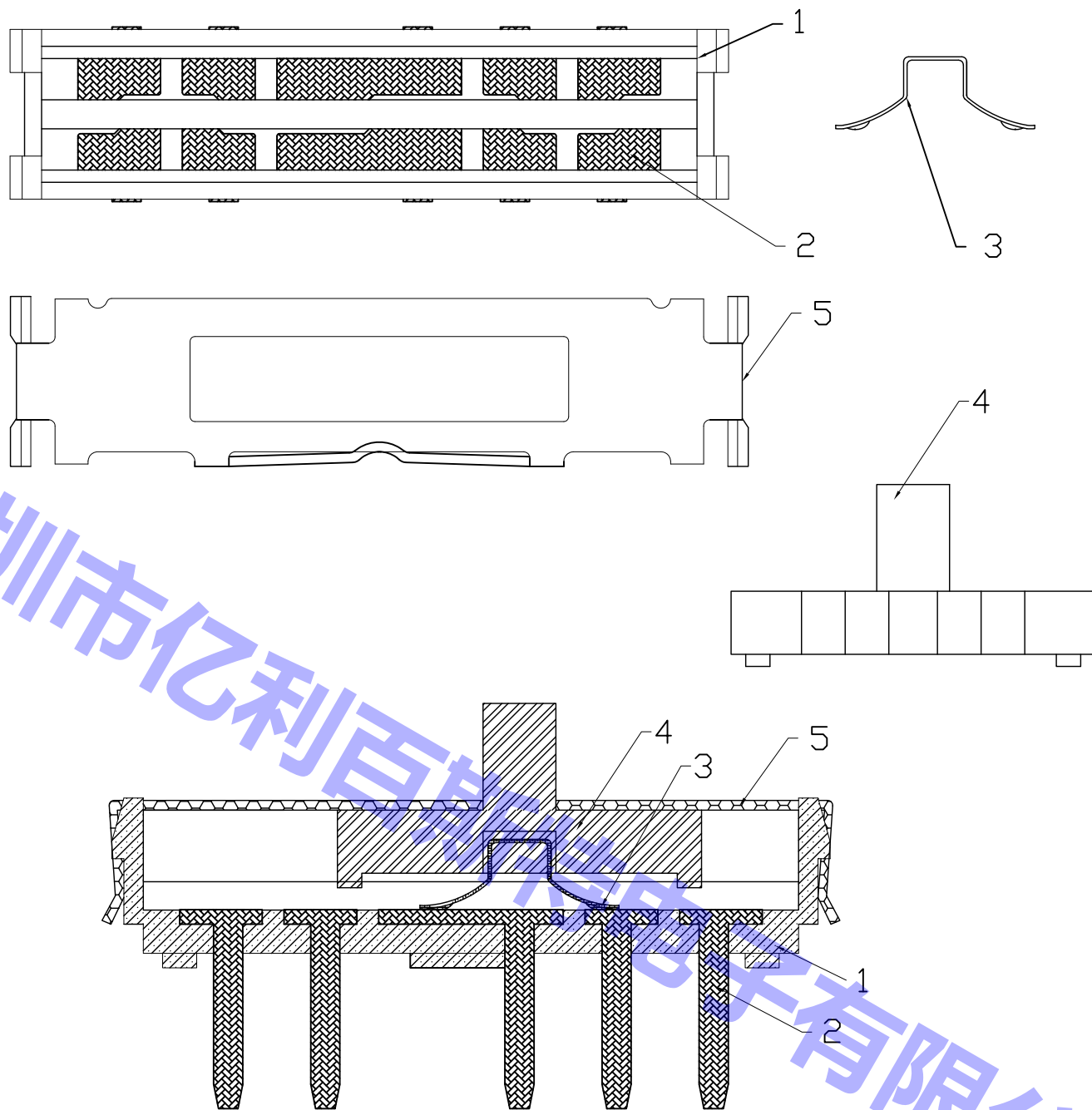

项目	零件	材料	颜色	数量
1	塑胶本体	PA6T	黑色	1
2	五金端子	磷铜镀银	银白色	10
3	接触簧片	铍青铜镀银	银白色	2
4	塑胶推柄	PA46	黑色	1
5	五金盖板	不锈钢	本色	1

深圳市亿利百斯特电子有限公司

结构图

制定	核对	审批	日期	备注
----	----	----	----	----

此数据仅供参考，实际以样品为准

深圳市亿利百斯特电子有限公司		文件编号	CM/GGS-20180817001
		发布日期	2018年8月17日
SPECIFICATION 规格书		版 本	A/0
产品名称：拨动开关		产品型号：EL-MSK56A	
1: GENERAL SPECIFICATION 基本事项			
1.1	RATING (额定值): DC 12V 100mA		
1.2	PRACTICAL TEMPERATURE RANGE: -10°C~+50°C. 使用温度范围: 在-10°C~+50°C温度内使用.		
1.3	STANDARD ATMOSPHERIC CONDITIONS : UNLESS OTHERWISE SPECIFIED. THE STANDARD RANGE OF ATMOSPHERIC CONDITIONS FOR MAKING MEASUREMENTS AND TESTS ARE AS FOLLOWS: (1) AMBIENT TEMPERATURE : 5°C TO 35°C; (2) RELATIVE HUMIDITY : 45% TO 85%; (3) AIR PRESSURE : 86Kpa TO 106Kpa. 测试标准状态: 在沒有指定的情況下测试温度, 湿度, 气压如下: (1) 温度为5~35°C; (2) 湿度为45%~85%; (3) 气压为86Kpa~106Kpa.		
2. ELECTRICAL CHARACTERISTICS (电气性能规格):			
ITEM	项目	TEST CONDITIONS 测试条件	PERFORMANCE (DATA) 规格(数据)
2.1	CONTACT RESISTANCE 接触电阻	MEASURED AT 1KHz SMALL CURRENT (100 mA OR LESS) 在1KHz微小电流(100mA 以下)测试.	100mΩ MAX. 100毫欧以下. (初始值)
2.2	INSULATION RESISTANCE 绝缘电阻	APPLY A VOLTAGE OF 100V . THE FOLLOWING CONTACT TEST METHOD: (1) BETWEEN BODY AND CONDUCTOR. (2) BETWEEN CONDUCTORS NOT TO BE CONTACT. 输入100V DC电压, 按以下接触方法测试: (1) 接触端子之间. (2) 胶座体和排脚之间.	50MΩ MIN. 50兆欧以上.
2.3	VOLTAGE PROOF 耐电压	AC 250V (50-60Hz) FOR 1 MIN TRIP CURRENT: 0.5mA THE FOLLOWING CONTACT TEST METHOD: (1) BETWEEN TERMINALS. (2) BETWEEN INDIVIDUAL TERMINALS AND FRAME. 输入AC250V (50-60Hz) 电压, 1分钟感度电流为0.5mA, 接触测试方法如下: (1) 接触端子之间. (2) 外壳体和排脚之间.	WITHOUT DAMAGE TO PARTS ARCING OR BREAKDOWN ETC. 没有绝缘破坏等异常
3. MECHANICAL CHARACTERISTICS (机械性能规格)			
ITEM	项目	TEST CONDITIONS 测试条件	PERFORMANCE (DATA) 规格(数据)
3.1	OPERATING FORCE 动作力	LATERAL PUSH (侧向推动)	PUSH FORCE (按压力度): 230gf ± 70gf
3.2	TRAVEL 动作行程	IN THE HORIZONTAL DIRECTION SWITCH HANDLE OPERATION, WITH AN EQUAL TO 1TIMES THE THRUST OF THE SWITCH FROM ONE POSITION TO THE NEXT GEAR, MOVING DISTANCE MEASURING HANDLE. 在开关推柄运行的水平方向, 以一个等于1倍推力使开关从一个档位运动到下一档位, 测量推柄的移动距离.	2.0 ± 0.2mm
3.3	STEM STRENGTH 操作部(柄)强度	AND ALONG THE RUNNING DIRECTION AT APEX HANDLE (4N) ON THE STRENGTH TEST, TIME IS 30 SECONDS. 在推柄的先端沿运行方向加上(4N)力度测试, 时间为30秒.	外观无异常, 满足于机械, 电气性能

深圳市亿利百斯特电子有限公司		文件编号	CM/GGS-20180817001
		发布日期	2018年8月17日
SPECIFICATION 规格书		版 本	A/0
产品名称：拨动开关		产品型号：EL-MSK56A	
4. DURABILITY (耐久性) :			
ITEM	项目	TEST CONDITIONS 测试条件	PERFORMANCE (DATA) 规格 (数据)
4.1	LIFE TEST 寿命试验	AN ACTUATOR SHALL BE WITH A THRUST OF NO GREAT THAN 1 TIMES SWITH POWER TO 10000 CYCLES AT A SPEED OF 30 CYCLES FOR 1 MIN. 操作者以每分钟30次的频率，施加不大于开关1倍的推力做10000次无负荷测试。	1) CONTACT RESISTANCE SHALL BE $\geq 300m\Omega$ . 2) LIFETIME: 10000次 1) 接触电阻 $\geq 300m\Omega$ . 2) 寿命: 10000次
4.2	HEAT RESISTANCE 耐热实验	THE SWITCH SHALL BE STORED AT A TEMPERATURE OF $85\pm 2^{\circ}C$ FOR 96 HOURS. AND THEN IT SHALL BE SUBJECTED TO THE CONTROLLED RECOVERY CONDITIONS FOR 1 HOUR AFTER WHICH MEASUREMENT SHALL BE MADE. 放置在温度 $85\pm 2^{\circ}C$ 中96小时后，再放置正常室温中1小时后测定。	THERE SHALL BE NO DAMAGE ON APPEARANCE. MECHANICAL AND ELECTRICAL CHARACTERISTICS SHALL BE SATISFIED. 外观无异常，满足于机械，电气性能
4.3	COLD RESISTANCE 耐冷实验	THE SWITCH SHALL BE STORED AT A TEMPERATURE OF $-25\pm 3^{\circ}C$ FOR 96 HOURS. AND THEN IT SHALL BE SUBJECTED TO THE CONTROLLED RECOVERY CONDITIONS FOR 1 HOUR AFTER WHICH MEASUREMENT SHALL BE MADE. 放置在温度 $-25\pm 3^{\circ}C$ 中96小时后，再放置正常室温中1小时后测定。	
4.4	HUMIDITY TEST 潮湿实验	THE SWITCH SHALL BE STORED AT A TEMPERATURE OF $40\pm 2^{\circ}C$ AND A HUMIDITY OF 80% TO 85% FOR 96 Hr. THEN THE JACK SHALL BE MAINTAINED AT STANDARD ATMOSPHERIC CONDITION FOR 1 Hr FOR OTHER PROCEDURES. 放置在 $40\pm 2^{\circ}C$ 相对湿度为80~85%环境中96小时后，再将样品放在正常室温中1小时后测定。	
4.5	TEMPERATURE CYCLE 温度循环	DECREASE FROM $25^{\circ}C$ TO $-25^{\circ}C$ IN 30 MINUTES; THEN INCREASE FROM $-25^{\circ}C$ TO $85^{\circ}C$ TO COMPLETE ONE CYCLE. TOTAL 5 CYCLES. MEASURE AFTER 1 HOURS OF RECOVERY IN STANDARD ATMOSPHERIC CONDITIONS. 从 $25^{\circ}C$ 减少到 $-25^{\circ}C$ ；时间30min，温度再从 $-25^{\circ}C$ 增加到 $85^{\circ}C$ 为一个循环，共循环5次。在标准大气条件下，恢复1h后测试。	
		<p>The diagram illustrates a temperature cycle. It starts at 25°C, ramps down to -25°C in 30 minutes, holds at -25°C for 30 minutes, ramps up to 85°C in 30 minutes, and holds at 85°C for 30 minutes. This sequence is labeled as '1 cycle'.</p>	

深圳市亿利百斯特电子有限公司	文件编号	CM/GGS-20180817001
	发布日期	2018年8月17日
SPECIFICATION 规格书	版 本	A/0

产品名称: 拨动开关

产品型号: EL-MSK56A

4. DURABILITY (耐久性):

ITEM 项目	TEST CONDITIONS 测试条件	PERFORMANCE (DATA) 规格(数据)
4.6 24 HOUR SALT SPRAY TEST 24小时盐雾测试	1) SALT SOLUTION MASS CONCENTRATION (5 ± 0.1)%; PH VALUE 6.5~7.2; SALT WATER BUCKET TEMPERATURE 35 ± 2°C, SPRAY PRESSURE 0.12MPa FOR 24 HOURS. SALT SPRAY COLLECTION 1.0~2.0ml/ (80cm <sup>2</sup> .H). 2) SALT SEDIMENT WATER WASHED OUT AFTER TEST AFTER DRY DRYING AFTER STANDING FOR 30 MINUTES TO DETECT. 1) 盐溶液质量百分比浓度 (5 ± 0.1) %; PH值6.5~7.2; 盐水桶温度35 ± 2°C; 喷雾压力0.12MPa连续喷雾24小时; 盐雾收集量1.0~2.0ml/ (80cm <sup>2</sup> .H) 2) 试验后的盐沉积物用水冲掉后吹干静置30分钟后检测。	NO REMARKABLE CORROSION SHALL BE RECOGNIZED IN METAL PART 在金属件上没有影响开关性能的斑点

5 . SOLDERING PROPERTIES (焊接性能)

ITEM 项目	TEST CONDITIONS 测试条件	PERFORMANCE (DATA) 规格(数据)
5.1 SOLDERING CONDITIONS 焊锡条件	1) HAND SOLDERING 手焊: DIVCE 工具: SOLDER IRON 电烙铁. 270°C MAX., 3 sec Max 2) REFLOW SOLDERING 回流焊: ≤250°C 	THERE SHALL BE NO DAMAGE ON APPEARANCE. MECHANICAL AND ELECTRICAL CHARACTERISTICS SHALL BE SATISFIED. 外观无异常, 满足于机械, 电气性能

PREPARED 制定:

CHECKED 核对:

APPROVED 审批:



图1  
成品



图2  
成品袋装

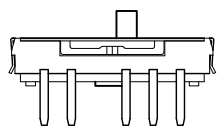

图3 内塑胶盒装

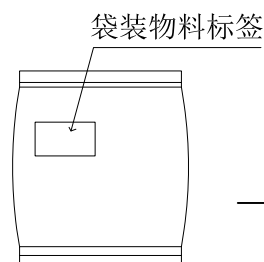

图4  
外箱

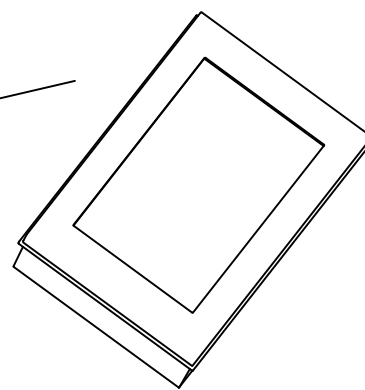

图5

外箱物料标签

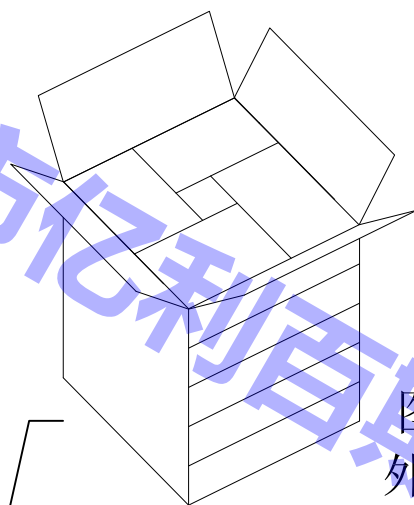
说明:

- 1: 如图2, 袋装后贴上物料标签, 每小袋装500pcs。
- 2: 如图3, 每塑胶盒装6小袋, 装盒后贴上物料标签, 数量为6X500pcs。
- 3: 如图4, 每外箱一层装4内盒, 共5层, 数量为5X (4X6X500pcs)。
- 4: 如图5, 封箱贴上物料标签。

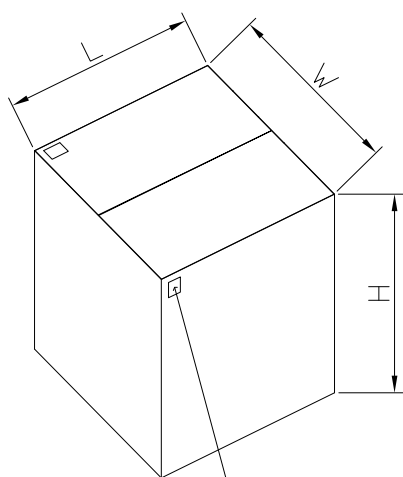
名称

型号

L

W

H

包装示意图

EL-MSK56A

365

365

380

深圳市亿利百斯特电子有限公司  
ShenZhen ElyBest Electronics Co., Ltd

备注

制定

核对

审批

日期

尺寸单位

此数据仅供参考, 实际以样品为准

mm