

# 承認書

APPROVE SHEET



敬請承認如下之形式規格書：

客戶名稱

CUSTOMER: \_\_\_\_\_

貴公司製品名

本公司製品名：

CUSTOMER PN: \_\_\_\_\_ PRODUCT PN: \_\_\_\_\_

貴公司規格

本公司規格：

APPROVAL DAT: \_\_\_\_\_ PRODUCT CODE: \_\_\_\_\_

客戶料號：

本公司規格書編號：

CUSTOMER NO.: \_\_\_\_\_ PRODUCT DRAWING NO.: \_\_\_\_\_

新品承認

NEW APPROVE

規格變更再承認

CHANGE CODE APPROVE  
AGAIN

材料變更再承認

CHANGE MATERIAL APPROVE  
AGAIN

APPROVAL

批准

DATE:

CHECK

審查

DATE:

DESIGN

設計

DATE:

貴公司承認欄

APPROVAL SIGNATURES

請於\_\_\_\_年\_\_\_\_月\_\_\_\_日前承認返回

日期 DATE: \_\_\_\_\_

PLEASE RETURN TO ADMIT XUNIANRURI

 <b>深圳市亿利百斯特电子有限公司</b>		文件编号	
		发布日期	2009年6月14日
SPECIFICATION 规格书		第2版	1 of 2
产品名称: 拨动开关			
产品型号			
DRAW 制定	刘明玲	APPD.审批	颜怀亮
1. RATING(额定值): DC 12V 50mA			
2. ELECTRICAL CHARACTERISTICS(电气性能规格):			
ITEM 项目		TEST CONDITIONS 测试条件	PERFORMANCE 规格
2.1	CONTACT RESISTANCE 接触电阻	MEASURED AT SMALL CURRENT(100mA OR LESS) 在微小电流(100mA)以下测试.	100mΩ MAX. 100 毫欧以下.
2.2	INSULATION RESISTANCE 绝缘电阻	APPLY A VOLTAGE OF 100V DC FOR 1 MIN. TO FOLLOWING PORTIONS AFTER WHICH MEASUREMENT SHALL BE MADE. 1) BETWEEN BODY AND CONDUCTOR. 2) BETWEEN CONDUCTORS NOT TO BE CONTACT. 输入 100V DC 电压 1 分钟, 按以下接触方法测试: 1) 接触端子之间; 2) 胶座体与排脚之间.	100MΩ MIN. 100 兆欧以上.
2.3	DIELECTRIC STRENGTH 耐电压	AC 250V (50-60Hz) FOR 1 MIN TRIP CURRENT: 0.5mA 1) BETWEEN TERMINALS. 2) BETWEEN INDIVIDUAL TERMINALS AND FRAME. 输入 AC 250V(50-60Hz)电压, 1 分钟感度电流为 0.5mA, 按以下接触方法测试: 1) 排脚相互之间; 2) 排脚与外壳之间.	WITHOUT DAMAGE TO PARTS ARCING OR BREAKDOWN ETC. 没有绝缘破坏等异常.
3. MECHANICAL CHARACTERISTICS(机械性能规格)			
ITEM 项目		TEST CONDITIONS 测试条件	PERFORMANCE 规格
3.1	OPERATING FORCE 动作力	横向推动	200gf ± 40 gf
3.2	TERMINAL STRENGTH 端子强度	A STATIC LOAD OF (500gf) SHALL BE APPLIED TO THE TIP OF THE TERMINAL FOR 1 MIN IN ANY DIRECTION. 在任意一个方向的先端加上(500gf)力度测试,时间为1分钟 .	ELECTRICAL CHARACTERISTICS SHALL BE SATISFIED WITHOUT DAMAGE OR EXCESSIVE LOOSENESS OF ACTUATOR 在端子中没有裂开, 松动等异常, 满足于机械, 电器性能.
3.3	STANDARD ATMOSPHEIC CONDITIONS 测试标准状态	UNLESS OTHERWISE SPECIFIED. THE STANDARD RANGE OF ATMOSPHERIC CONDITIONS FOR MAKING MEASUREMENTS AND TESTS ARE AS FOLLOWS: 1) AMBIENT TEMPERATURE: 5°C TO 35°C 2) RELATIVE HUMIDITY: 45% TO 85% 3) AIR PRESSURE: 80Kpa~106Kpa. 在没有指定的情况下测试温度,湿度,气压如下: 1) 温度为 5°C~35°C; 2) 湿度为 45%~85%; 3) 气压为 80Kpa~106Kpa.	



3.4	PRACTICAL TEMPERATURE RANGE 使用温度范围	-16°C~+60°C. 在-16°C~+60°C温度内使用.
-----	---------------------------------------	------------------------------------

**4. DURABILITY(耐久性):**

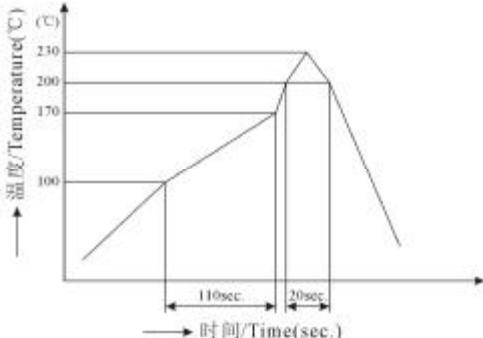
ITEM 项目	TEST CONDITIONS 测试条件	PERFORMANCE 规格
4.1 LIFE TEST 寿命试验	WITHOUT LOAD: AN ACTUATOR SHALL BE SUBJECT TO 10,000 CYCLES AT A SPEED OF 10 CYCLES FOR 1 MIN. 无负荷: 操作者以每分钟 10 次的频率作 10,000 回之无负荷测试.	1) CONTACT RESISTANCE SHALL BE 200mΩ MAX. 2) MECHANICAL AND ELECTRICAL CHARACTERISTICS SHALL BE SATISFIED. 1) 接触电阻不能超过于 200mΩ 2) 其它满足于机械, 电气性能.
4.2 HEAT TEST 耐热试验	THE SWITCH SHALL BE STORED AT A TEMPERATURE OF 85±2°C FOR 96 HOURS. AND THEN IT SHALL BE SUBJECTED TO THE CONTROLLED RECOVERY CONDITIONS FOR 1 HOUR AFTER WHICH MEASUREMENT SHALL BE MADE. 放置在温度 85±2°C 中 96 小时后,再放置正常室温中 1 小时后测定.	THERE SHALL BE NO DAMAGE ON APPEARANCE. MECHANICAL AND ELECTRICAL CHARACTERISTICS SHALL BE SATISFIED. 外观无异常, 满足于机械, 电气性能.
4.3 COLD TEST 耐冷试验	THE SWITCH SHALL BE STORED AT A TEMPERATURE OF -25±3°C FOR 96 HOURS. AND THEN IT SHALL BE SUBJECTED TO THE CONTROLLED RECOVERY CONDITIONS FOR 1 HOUR AFTER WHICH MEASUREMENT SHALL BE MADE. 放置在温度 -25±3°C 中 96 小时后,再放置正常室温中 1 小时后测定.	THERE SHALL BE NO DEFORMATION OR CRACKS IN MOLDED PART. 外观无异常, 满足于机械, 电气性能.
4.4 HUMIDITY TEST 潮湿试验	THE SWITCH SHALL BE STORED AT A TEMPERATURE OF 40±2°C AND A HUMIDITY OF 90% TO 96% FOR 96 HOURS. THEN THE SWITCH SHALL BE MAINTAINED AT STANDARD ATMOSPHERIC CONDITIONS FOR 1 HOUR FOR OTHER PROCEDURES BE MADE. 放置在 40±2°C 相对湿度为 90~96% 环境中 96 小时后, 再将样品放在正常环境中 1 小时后进行测定.	外观无异常, 满足于机械, 电气性能.
4.5 SOLDERING CONDITIONS 焊锡条件	HAND SOLDERING 手焊: 1) DIVICE 工具: SOLDER IRON 电烙铁. A. 350°C Max. 3sec Max. B. 270°C Max. 5sec Max. 2) REFLOW SOLDERING 回流焊: 250度.  	THERE SHALL BE NO DEFORMATION OR CRACKS IN MOLDED PART. 外观无异常, 满足于机械, 电气性能.

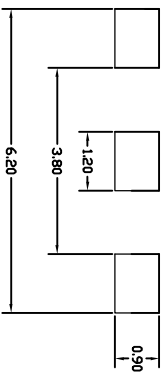
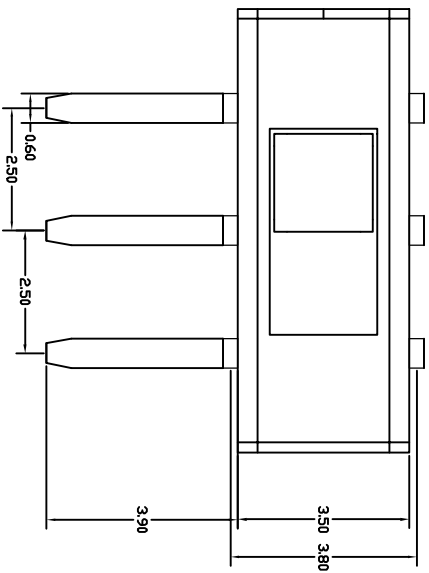
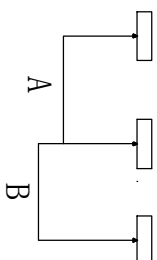
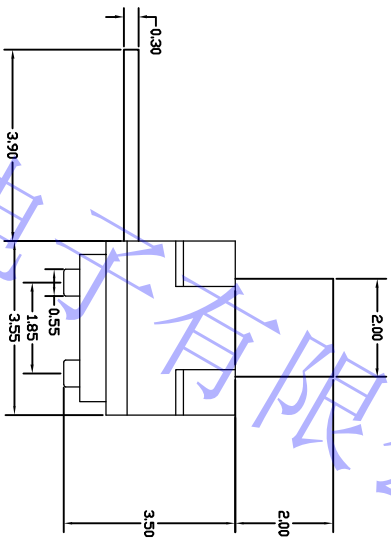
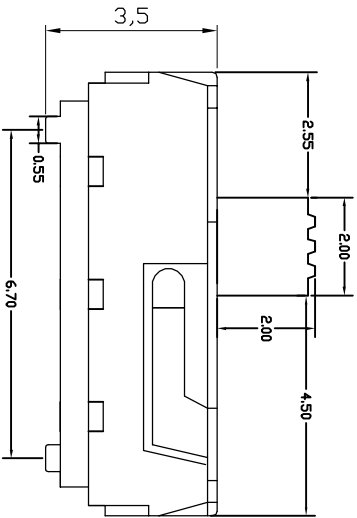

项目	规格
额定电负荷:	DC12V 0.1A
绝缘电阻:	$\geq 100M\Omega$
耐压强度:	AC250V (50Hz) 1min
环境温度:	-25 °C ~ +70 °C
相对湿度:	(40 °C) $\leq 95\%$
接触电阻:	$\leq 50M\Omega$
动作力:	200gf $\pm$ 40gf
耐温:	260 °C
寿命:	10000次

<b>拨动开关</b>	
EL-MSK38 宽柄	

序号	名称	数量	材料	镀涂颜色
D	接触簧片	2	铍青铜	银白色
C	盖子	1	不锈钢	灰色
B	底座	1	进口增强尼龙	黑色与镀银
A	推柄	1	进口增强尼龙	黑色

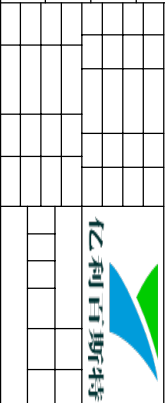

深圳市亿利百斯特电子有限公司