

# 承認書

APPROVE SHEET



敬請承認如下之形式規格書：

客戶名稱

CUSTOMER: \_\_\_\_\_

貴公司製品名

本公司製品名：

輕觸開關

CUSTOMER PN: \_\_\_\_\_

PRODUCT PN: \_\_\_\_\_

TACT SWITCH

貴公司規格

本公司規格：

APPROVAL DAT: \_\_\_\_\_

PRODUCT CODE: \_\_\_\_\_

EL-1212WP

客戶料號：

本公司規格書編號：

CUSTOMER NO.: \_\_\_\_\_

PRODUCT DRAWING NO.:

Q/EL-JS0885-2004

新品承認

NEW APPROVE

規格變更再承認

CHANGE CODE APPROVE

AGAIN

材料變更再承認

CHANGE MATERIAL APPROVE

AGAIN

APPROVAL

批准



DATE:

CHECK

審查



DATE:

DESIGN

設計



DATE:

貴公司承認欄

APPROVAL SIGNATURES

請於\_\_\_\_年\_\_\_\_月\_\_\_\_日前承認返回

日期 DATE: \_\_\_\_\_

PLEASE RETURN TO ADMIT XUNIANRURI

深圳市亿利百斯特电子有限公司

ShenZhen ElyBest Electronics Co., Ltd

付文鹏 (Vincent Fu)

Tel : 0755-28213003

Fax: 0755-85215085

Mob: 18923844556

Email : vincent@elybest.com



深圳市亿利百斯特电子有限公司  
ShenZhen ElyBest Electronics Co., Ltd

文件编号  
FILE NO.

EL-1212WP

发布日期  
DATE OF ISSUE

2009年3月18日

规格书  
SPECIFICATION

第A版  
VERSION NO. A

第1页 共7页  
Page one of seven

产品系列  
SERIES

轻触开关  
TACT SWITCH

产品型号  
TYPE

轻触系列

## 1、概述

### 1.1 适用范围

此规格书适用于机械式轻触开关的相关要求

#### 1. 温度范围：

Temperature range:

1.1 保存的温度范围： -25℃~85℃

Storage Temperature range -25℃ to 85℃

1.2 使用的温度范围： -15℃~60℃

Temperature range for use -15℃ to 60℃

#### 2. 测试环境条件：

Test circumstance condition:

环境温度： 16℃

Ambient temperature 16℃

相对湿度： 63%~95%

Relative humidity 63% to 95%

空气压力： 102 千帕

Air pressure 102KPa

#### 3. 外观、结构和尺寸：

Appearance、 Structure and Dimension:

##### 3.1 外观：

Appearance:

没有生锈，伤痕、电镀不良，破裂，剥离现象。动作正常，换位清晰。

Functionally free from rust, crack and bad plating.

##### 3.2 结构和尺寸

Structure and Dimension:

参照有关外形图

Reference per attached outline drawing.

4. 额定值： DC 12 V 0.5A

Rating: DC 12 V 0.5A

 <b>深圳市亿利百斯特电子有限公司</b> ShenZhen ElyBest Electronics Co., Ltd		文件编号 FILE NO.	EL-1212WP
		发布日期 DATE OF ISSUE	2009年3月18日
规格书 SPECIFICATION		第 A 版 VERSION NO. A	第 2 页 共 7 页 Page two of seven
产品系列 SERIES	轻触开关 TACT SWITCH	产品型号 TYPE	轻触系列
5. 机械性能: Mechanical performance:			
项目 Items	试验条件 Test conditions		规格 Requirements
5.1 按力 Press force	开关垂直于操作方向放置, 在驱动件顶端中心逐渐施力, 测量开关导通所需的最大力度。 Placing the switch such that the direction of switch operation is vertical, and then gradually increasing the load applied to the center of the knob the maximum load for the knob to come to a stop shall be measured.		1.6±0.5N or 2.6±0.5N
5.2 回弹力 Return force	开关垂直于操作方向放置, 驱动件顶端中心下降至全行程后, 测量顶端向自由位置返回的力度。 The sample switch is installed such that the direction of switch operation is vertical, and upon depression of knob in its center the whole travel distance, the force of the knob to return to its free position shall be measured.		0.6±0.3N or 1.0±0.5N
5.3 行程 Travel	开关垂直于操作方向放置, 以一个等于 2 倍按力的静负荷施加于驱动件顶端中心, 测量顶端的移动距离。 Placing the switch such that the direction of switch operation is vertical and then applying a static load twice the operating force to the center of the knob, the travel distance for the knob to come to a stop shall be measured.		0.45±0.1mm
5.4 驱动件强度 Actuator Strength	在驱动件顶端面中央, 施加 10 牛顿的力于按压方向的停止位上 5 秒。 To the press direction 10N until the stop for 5 sec.		满足 5.1、6.1-6.3 项要求且操作元件不被损坏或太松。 Item 5.1、6.1 to 6.3 shall be satisfied. Without damage of actuator. Function and action is in gear.

 <b>深圳市亿利百斯特电子有限公司</b> ShenZhen ElyBest Electronics Co., Ltd		文件编号 FILE NO.	EL-1212WP
		发布日期 DATE OF ISSUE	2009年3月18日
规格书 SPECIFICATION		第 A 版 VERSION NO. A	第 3 页 共 7 页 Page three of seven
产品系列 SERIES	轻触开关 TACT SWITCH	产品型号 TYPE	轻触系列
项目 Items	试验条件 Test conditions		规格 Requirements
5.5	接线端强度 Connection Port Strength	接线端任意方向施加 10 牛顿的力，持续时间： 10±1 秒。 To any the connection place pull 10N, 10±1sec.	接线端无损伤，脱落； 功能动作正常 Without damage of connection Port function and action is in gear.
5.6	可焊性 Solder-Ability	蒸汽老化 1 小时后。端子的焊接部分浸入温度为 235±5℃熔融的焊锡内 2±0.5 秒。 An hour later, the steam ageing. The soldering area of the terminal shall be immersed into molten solder at a temperature of 235±5℃ for 2±0.5sec.	大于浸入部分的 90% 被焊锡覆盖。 More than 90% of the dipping part shall be covered by solder.
5.7	耐焊接热 Soldering heat resistance	端子的焊接部分浸入温度为 260±5℃熔融的焊锡内 3±1 秒。 The soldering area of the terminal shall be immersed into molten solder at a temperature of 260±5℃ for 3±1 sec.	1) 不能出现变形 There shall not be deforming in appearance 2) 满足 5.1, 6.1 到 6.3 项要求 The requirements specified in Item 5.1, 6.1 to 6.3 shall be satisfie.
6. 电气性能: Electrical performance:			
6.1	接触电阻 Contact Resistance	电压: DC 5V Rating: DC 5V 电流: 100±2mA Current: 100±2mA	25 毫欧以下 25mΩ or less
6.2	绝缘电阻 Insulation resistance	DC 100V. 1 分钟后进行测量 A voltage of 100V. DC shall be applied for 1 min after which measurement shall be made.	100 兆欧以上 100MΩ or more
		端子相互间 Between terminals 每一端子和外壳间 Between individual terminal and frame	

 <b>深圳市亿利百斯特电子有限公司</b> ShenZhen ElyBest Electronics Co., Ltd		文件编号 FILE NO.	EL-1212WP
		发布日期 DATE OF ISSUE	2009年3月18日
规格书 SPECIFICATION		第 A 版 VERSION NO. A	第 4 页 共 7 页 Page four of seven
产品系列 SERIES	轻触开关 TACT SWITCH	产品型号 TYPE	轻触系列
项目 Items	试验条件 Test conditions		规格 Requirements
6.3	耐压 Withstand Voltage	250V.AC/50HZ 1 分钟 250V.AC/50Hz for 1 min,	端子相互间 Between terminals 每一端子和外壳间 Between individual terminal and frame
6.4	振动 Librate	振频 10-500Hz 振幅位移幅值: 0.35mm; 加速度幅值: 50m/s <sup>2</sup> , 每次扫描时间: 11 分钟。 共进行 5 次循环。 Librate frequency:10-500Hz Swing : Extent cost displacement should be 0.35mm; The accelerated extent cost should be 50m/s <sup>2</sup> . The scan time:11 minutes once a time. Do it for five times.	应无闪弧及击穿现象。漏电流<0.5mA. No arcing or break down shall occur. Trip current<0.5mA. 应满足 6.1 项, 外观无明显异常, 功能动作应正常 Item 6.1 shall be satisfied, the facade of the switch have no abnormity , motion and function is good.
7. 耐候性 Weatherality			
7.1	恒定湿热 Invaria-Blenes Damp Heat	放置在温度为 40±2℃, 相对湿度为 90-95% 的环境中 96 小时, 然后再放在标准大气环境中 1 小时, 在此后 1 小时内进行测量。 Switch for test shall be stored at a temperature 40±2℃ ,and a relative humidity of 90-95% for 96 hours. Then the switch shall be maintained at standard atmospheric conditions for an hour after which measurement shall be made within 96hour.	接触电阻. 参照 6.1 Contact resistance. Refer to Item 6.1 100 毫欧以下 100mΩ or less 绝缘电阻. 参照 6.2 Insulation resistance. Refer to Item 6.2 10 兆欧以上 10MΩ or more 耐电压. 参照 6.3 Withstand voltage. Refer to Item 6.3 应无闪弧及击穿现象 No arcing or break down Shall occur. 操作力和外观 Operating force and appearance 满足第 5.1 中的要求, 塑件没有出现变形或裂纹, 没有出现严重变色及生锈。 Item 5.1 shall be satisfied , there shall be no deformation or cracks in molded part or excessive rust and discoloration.



深圳市亿利百斯特电子有限公司

文件编号  
FILE NO.

EL-1212WP

发布日期  
DATE OF ISSUE

2009年3月18日

规格书  
SPECIFICATION

第 A 版  
VERSION NO. A

第 5 页 共 7 页  
Page five of seven

产品系列  
SERIES

轻触开关  
TACT SWITCH

产品型号  
TYPE

轻触系列

项目  
Items

试验条件  
Test conditions

规格  
Requirements

7.2

高温  
Dry heat  
proof

储放在 70±2℃ 的温箱中 72 小时后, 在标准大气环境中放置 1 小时, 然后在 1 小时之内测量。  
Switch for test shall be stored at a temperature of 70±2℃ for 72 hours, and at standard atmospheric Conditions for 1hour then to be measured within an hour.

满足第 3.1, 5.1, 6.1 至 6.3 中的要求  
The Item 3.1, 5.1, 6.1 to 6.3 shall be satisfied.

7.3

低温  
Cold  
Proof

储放在 -25±3℃ 的冰箱中 16 小时后, 在标准大气环境中放置 1 小时, 然后在 1 小时之内测量。  
Switch for test shall be stored at a temperature of -25±3℃ for 16 hours, and at standard atmospheric conditions for 1hour then to be measured within 1 hour.

7.4

防护等级  
Degree of  
protec tion

符合 GB4208-93 IP67 要求  
Accord with GB4208-93  
IP 67 Requi rement

将产品放置在 0.15m-1m 清水中, 常温下试验时间 30min 后晾干不影响产品性能. Lays aside the product in the 0.15m-1m clear water, under after normal temperature

8. 耐久性能  
Durability

8.1

寿命试验  
Life Test

50,000 cycles of a knob operation shall be performed continuously at a rate of 2~3 cycles/sec. 操作元件以每秒钟 2~3 次的速度连续完成 50,000 次动作。

按力. 参照 5.1  
Press force. Refer to Item 5.1

初始力度值±30%  
±30% of initial force

接触电阻. 参照 6.1  
Contact resistance .Refer to Item 6.1

100 毫欧以下  
100 mΩ or less

绝缘电阻. 参照 6.2  
Insulation resistance. Refer to Item 6.2

10 兆欧以上  
10 MΩ or more

耐电压. 参照 6.3  
Withstand voltage. Refer to Item 6.3

应无闪弧及击穿  
No arcing or Break down shall occur.

 <b>深圳市亿利百斯特电子有限公司</b> ShenZhen ElyBest Electronics Co., Ltd		文件编号 FILE NO.	EL-1212WP
		发布日期 DATE OF ISSUE	2009年3月18日
规格书 SPECIFICATION		第 A 版 VERSION NO. A	第 6 页 共 7 页 Page six of seven
产品系列 SERIES	轻触开关 TACT SWITCH	产品型号 TYPE	轻触系列
9. 焊接条件: Soldering conditions:			
项目 Items		推荐条件 Recommended conditions	
9.1	手工焊接 Hand soldering	<p>请按以下条件进行焊接:</p> <p>(1) 焊锡温度: <math>\leq 360^{\circ}\text{C}</math></p> <p>(2) 连续焊接时间: <math>\leq 3\text{ s}</math></p> <p>(3) 电烙铁的功率: <math>\leq 20\text{ W}</math></p> <p>Please practice according to below conditions:</p> <p>(1) Soldering temperature: <math>360^{\circ}\text{C}</math> Max.</p> <p>(2) Continuous soldering time: <math>3\text{ s}</math> Max.</p> <p>(3) Capacity of soldering iron : <math>20\text{ W}</math> Max.</p>	
9.2	自动焊接 Automatic flow soldering	<p>(1) 预热: 在 PWB 进入焊接装置后, 在 <math>2 \pm 0.3</math> 分钟内铜箔表面的温度应达到预热的最高温度 <math>180^{\circ}\text{C}</math>;</p> <p>(2) 焊接: 在 PWB 进入焊接热区域后, 最长 10 秒内铜箔表面的温度应达到 <math>260^{\circ}\text{C}</math> 的峰值温度;</p> <p>(3) 说明: 以上提及的条件是零部件上 PWB 表面的温度, 由于 PWB 的材料, 尺寸、厚度等不同 PWB 从开关表面获得的温度也会有很大的不同, 因此, 千万小心不要让开关表面的温度超过 <math>280^{\circ}\text{C}</math>。</p> <p>(1) Preheat: Temperature on the copper foil surface should reach preheat maximum temperature of <math>180^{\circ}\text{C}</math> within <math>2\text{min} \pm 0.3\text{min}</math>. after the PWB entered into the soldering equipment.</p> <p>(2) Soldering: Temperature on the copper foil surface should reach the peak temperature of <math>260^{\circ}\text{C}</math> within 10 seconds max. after the PWB entered into soldering heat zone.</p> <p>(3) Caution: The condition mentioned above is a temperature on the PWB surface on which parts are mounted. There are cases where PWB temperature greatly differs from switch's surface temperature depending on PWB material , size , thickness , etc . Care , therefore , should be used not to allow switch's surface temperature to exceed <math>280^{\circ}\text{C}</math>.</p>	



深圳市亿利百斯特电子有限公司  
ShenZhen ElyBest Electronics Co., Ltd

文件编号

FILE NO.

EL-1212WP

发布日期

DATE OF ISSUE

2009年3月18日

规格书

SPECIFICATION

第A版

VERSION NO. A

第7页 共7页

Page seven of seven

产品系列

SERIES

轻触开关

TACT SWITCH

产品型号

TYPE

轻触系列

技术要求:

- 1、此产品技术要求详细《产品规格书》;
- 2、H = 6-18mm, 未注公差:  $\pm 0.1\text{mm}$ ; 环保要求: 符合 ROHS 标准。

序号	部件名称	图号	部件材料	材料规格及符号	数量	备注
1	接线片	EL-1212WP	高精铜	H6.5Y 1-0.3	1	镀银
2	基座	EL-1212WP	增强尼龙	PPA	1	黑色
3	簧片	EL-1212WP	覆银铜带	AgCU	1	覆银
4	内按键	EL-1212WP	增强尼龙	PPA	1	黑色
5	防水膜	EL-1212WP	聚酰亚胺胶带	FX-830	1	橙黄色
6	防尘膜	EL-1212WP	硅橡胶	FX-580	1	黑色
7	盖板	EL-1212WP	增强尼龙	PPA	1	黑色
8	按键	EL-1212WP	增强尼龙	PPA	1	黑色



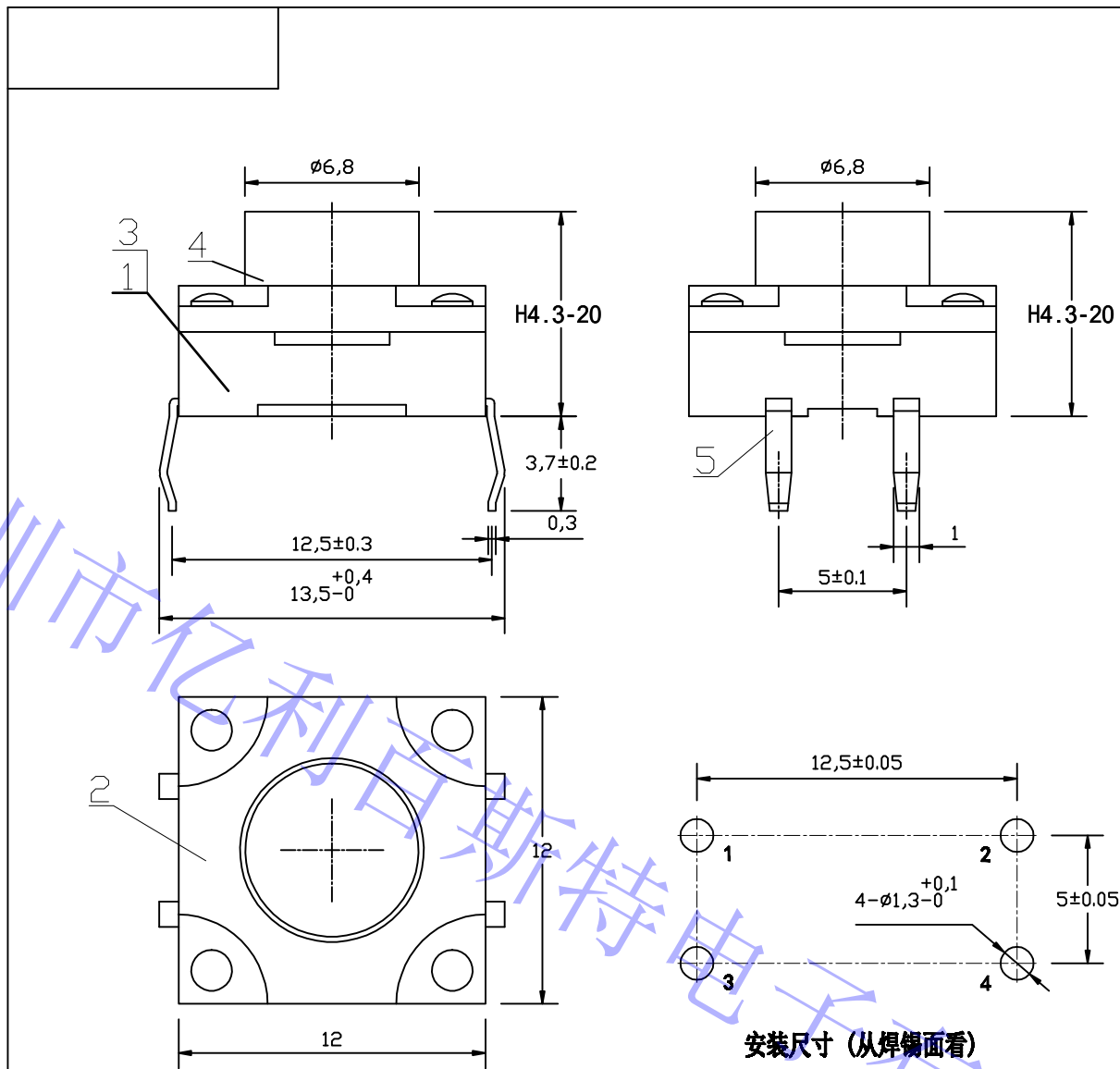

安装尺寸 (从焊锡面看)

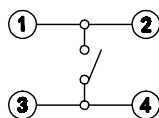

电路图表

未注公差:

角度	±5°
16 < L ≤ 80	±0.3
4 < L ≤ 16	±0.2
L ≤ 4	±0.1

环境条件 Environmental Conditions		额定负载 Rated Current Capacity	接触电阻 Contact Resistance	绝缘电阻 Insulation Resistance	耐压 Withstand Voltage	工作寿命 Life	接合力 Press Force
温度 Temperature	相对湿度 Relative Humidity						
-25~+85℃	95% (40℃)	0.5A/12V	≤25mΩ	≥100mΩ	AC250V	5万次	250±50gf

序号	部件名称	数量	材料	颜色/镀层	备注
7	垫子	1	增强PPA	G30	黑色
6	防水胶	1	硅胶	t=0.3	黑色
5	卡件	1	H62	t=0.3	镀Ag
4	按钮	1	增强PPA	G30	黑色
3	簧片	1	F. Ag*1/C5210-EH-TA	t=0.09或0.1	
2	盖板	1	增强PPA	G30	黑色
1	底座	1	增强PPA	G30	黑色

借(通)用件登记	
描图	
描校	
旧底图总号	
底图总号	
签字	
日期	

轻触开关					EL-1212WP			
外 型 图					深圳市亿利百斯特电子有限公司			
设计	处数	更改文件号	签字	日期	图样标记	视图	单位	比例
校核					S A B	mm		
审核					共 1 张		第 1 张	
工艺					ShenZhen ElyBest Electronics Co., Ltd			