

承認書

APPROVE SHEET



敬請承認如下之形式規格書：

客戶名稱

CUSTOMER: _____

貴公司製品名

本公司製品名：

輕觸開關

CUSTOMER PN: _____

PRODUCT PN: _____

TACT SWITCH

貴公司規格

本公司規格：

APPROVAL DAT: _____

PRODUCT CODE: _____

EL-3302B

客戶料號：

本公司規格書編號：

CUSTOMER NO.: _____

PRODUCT DRAWING NO.:

Q/EL-JS0885-2004

新品承認

NEW APPROVE

規格變更再承認

CHANGE CODE APPROVE

AGAIN

材料變更再承認

CHANGE MATERIAL APPROVE

AGAIN

APPROVAL

批准



DATE:

CHECK

審查



DATE:

DESIGN

設計



DATE:

貴公司承認欄

APPROVAL SIGNATURES

請於____年____月____日前承認返回

日期 DATE: _____

PLEASE RETURN TO ADMIT XUNIANRURI

深圳市亿利百斯特电子有限公司

ShenZhen ElyBest Electronics Co., Ltd

付文鹏 (Vincent Fu)

Tel : 0755-28213003

Fax: 0755-85215085

Mob: 18923844556

Email : vincent@elybest.com

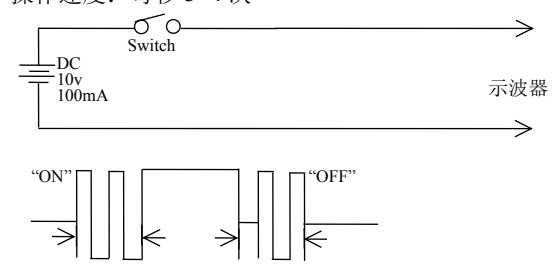
1.General specification 基本事项			
1.1 Switch action 开关种类: Tact Switch 轻触开关			
1.2 Switch rating 最大额定值: DC 12V, 50mA			
1.3 Operation temperature range 使用温度试验范围: -25℃~+85℃			
1.4 Preservative temperature range 保存温度范围: -40℃~+85℃			
1.5 Appearance and dimensions: See outside drawing page 外形尺寸: 见外形尺寸图			
1.6 Standard condition: Unless otherwise specified, the test and measurements shall be carried out as follows: 试验、测定状态 Ambient temperature 温度: 5~35℃ Relative humidity 相对湿度: 45~85% Air pressure 气压: 86~106KPa (860~1060mbar) However, if doubt arises on the decision based on the measured Values under the above-mentioned conditions, the following conditions be employed 但是在对判定产生疑义时, 按下述状态实施: Ambient temperature 温度: 20±2℃ Relative humidity 相对湿度: 65±5% Air pressure 气压: 86~106KPa (860~1060mbar)			
2.Performance 性能			
2.1 Electrical characteristics 电气性能			
Item 项目	Test condition 测试条件	Performance 规格	
2.1.1 Contact Resistance 接触电阻	Push force: (Operation force)x2 测定时的负荷: 操作方向动作力基准值的 2 倍 Measurement tool: Contact resistance meter 测定器: 微电流接触电阻计 (1KHz,20V,5~50mA)	100mΩ Max 100 毫欧以下	
2.1.2 Insulation Resistance 绝缘电阻	DC 250V(Between terminals) frame for 1 minute 不相接的两端子间、端子与塑胶间施加 DC250V 电压, 持续 1 分钟测量	100MΩ Min 100 兆欧以上	
2.1.3 Withstand Voltage 耐电压	AC 250V(Between terminals) frame for 1 minute 不相接的两端子间、端子与塑胶间施加 AC250V 电压, 持续 1 分钟测量	No insulation destruction 无绝缘破坏	
2.1.4 Bouncing 触点抖动	Operation speed:3~4times/s 操作速度: 每秒 3~4 次 	ON: 5ms max 以下 OFF: 5ms max 以下	

2.2 Mechanical Characteristics 机械性能			
Item 项目		Test condition 测试条件	Performance 规格
2.2.1	Operations Force 动作力	Push by recommended operating condition 测量时，轻触开关动作方向均匀施加静负荷。	250 ± 50gf
2.2.2	Travel to closure 运作行程	Push by recommended operating condition F=(Operations Force)x2 在开关的顶掇的面中央沿开关动作方向施加 2 倍操作力 测量行程，测量仪器的顶端应平。	0.15 ± 0.05mm
2.2.3	Push strength 按压强度	30N (3Kgf) for 1 minute 在开关驱动器件顶端中央，在垂直方向加 30N (3Kgf)力， 作用 60 秒	No damage(Electrical and mechanical) 无异常（电气、机械性能）
2.2.4	Vibration test 耐振性	1)Amplitude 全振幅：1.5mm 2)Sweep rate: 10-55-10Hz for 1 minute 扫描速度：10-55-10Hz 1 分钟 3) Sweep method: Logarithmic frequency sweep rate 扫描方式：对数频率扫描速度 4) Vibration direction: X、Y、Z (3 directions) 振动方向：X、Y、Z (3 方向) 5) Time: Each direction 2 hours(Total 6 hours) 时间：每个方向 2 个小时（共 6 个小时）	No.2.1 and 2.2.1 to 2.2.2 shall be satisfied 满足 2.1 项和 2.2.1 至 2.2.2 项。
2.2.5	Soldering heat test 耐焊接热	Soldering area: t/2 of P.W.B thickness (P.C.B: T=1.6mm) 焊接面积：印刷基板的 1/2 厚度处 Soldering temperature: 260 ± 5°C 焊接温度：260 ± 5°C Soldering time: 3 ± 0.5sec 焊接时间：3 ± 0.5 秒	No damage(Electrical and mechanical) 无异常（电气、机械性能）
2.2.6	Solderbility 可焊性	After sprated flux 涂上助焊剂后 Temperature: 245 ± 5°C 温度：245 ± 5°C Soldering time: 3 ± 0.5sec 焊接时间：3 ± 0.5 秒	90% or more of surface area of the portion immersed in solder shall be covered by new solder 90%或更多的浸焊面积能被焊锡覆盖

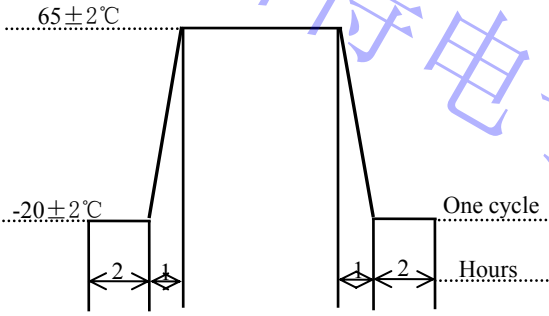
2.3 Climatic Characteristics 机械性能		
Item 项目	Test condition 测试条件	Performance 规格
2.3.1 Cold test 耐寒性	1) Temperature: $-20 \pm 2^{\circ}\text{C}$ 温度: $-20 \pm 2^{\circ}\text{C}$ 2) Duration of test: 48h 持续时间: 48 小时 3) Take off a drop water 去掉水珠 4) Standard conditions after test: 1h 试验后的放置条件: 1 小时	No.2.1 and 2.2.1 to 2.2.2 shall be satisfied 满足 2.1 项和 2.2.1 至 2.2.2 项。
2.3.2 Heat test 耐热性	1) Temperature: $70 \pm 2^{\circ}\text{C}$ 温度: $70 \pm 2^{\circ}\text{C}$ 2) Duration of test: 48h 持续时间: 48 小时 3) Standard conditions after test: 1h 试验后的放置条件: 1 小时	No.2.1 and 2.2.1 to 2.2.2 shall be satisfied 满足 2.1 项和 2.2.1 至 2.2.2 项。
2.3.3 Temperature cyclig test 温度并变试验	According to following figure, after 5cycles, test after Keeping in normal condition for 30min. 如图环境所示, 循环 5 次后, 放置在正常环境中, 1 小时 后进行测量。 	No.2.1 and 2.2.1 to 2.2.2 shall be satisfied 满足 2.1 项和 2.2.1 至 2.2.2 项。
2.3.4 Humidity test 耐湿性	1) Temperature: $40 \pm 2^{\circ}\text{C}$ 温度: $40 \pm 2^{\circ}\text{C}$ 2) Relative humidity: 90~95% 相对湿度: 90~95% 3) Duration of test: 48h 持续时间: 48 小时 4) Take off a drop water 去掉水珠 5) Standard conditions after test: 1h 试验后的放置条件: 1 小时	No.2.1 and 2.2.1 to 2.2.2 shall be satisfied 满足 2.1 项和 2.2.1 至 2.2.2 项。

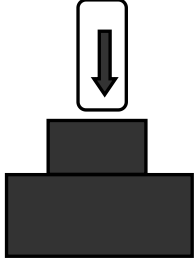
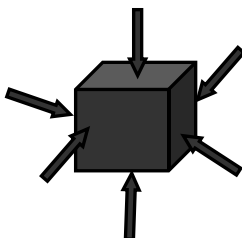
Item 项目	Test condition 测试条件	Performance 规格
2.3.5 Endurance (switching) action 耐久特性 (开关寿命)	1) Operation speed: 20~30times/min 动作速度: 20~30 次/分钟 3) Push force: Maximum vale of operation force 按力: 动作力规格值的上限 3) Operation number: 80, 000 times 动作次数: 80, 000 次 安装示意图 	Contact resistance: 200mΩ max 接触电阻: 200mΩ以下 Bouncing: 10 ms max 触点抖动: 10 毫秒以下 Insulation resistance: 100MΩ min 绝缘电阻: DC 250V, 大于 100MΩ Withstand voltage: No.destruction 耐电压: 无绝缘破坏 Variations rate of operation force shall be within ±30% to the value be fore testing 动作力的变化范围在初始值的±30%以内 2.2.2 shall be satisfied 满足 2.2.2 项
2.3.6 Withstand K ₂ S 耐 K ₂ S	1) Density: 3 ± 1ppm 浓度: 3 ± 1ppm 2) Temperature: 40 ± 2℃ 温度: 40 ± 2℃ 3) Relative humidity: 90~95% 相对湿度: 90~95% 4) Duration of test: 12h 持续时间: 12 小时 5) Standard conditions after test: 1h 试验后的放置条件: 1 小时	No.2.1 and 2.2.1 to 2.2.2 shall be satisfied 满足 2.1 项和 2.2.1 至 2.2.2 项。
2.3.7 Salt mist 盐雾试验	At 5% Nacl liquor for 8 ± 1 hours depend on 35℃, after washing, keep in normal condition. 5%的 Nacl 溶液, PH 值: 6.5~7.2, 在 35℃的条件下喷雾 8 ± 1 小时, 用清水洗干净后并在室温下晾干。	No remarkable corrosion shall be recognized in metal part. 在金属件上没有腐蚀斑点。
2.3.8 Shock 耐冲击性	Peak acceleration: 490m/S ² Duration of test: 11ms 冲击加速度: 490m/S ² 持续时间: 11ms Test time-6direction, each 3 times total 18 times 测试次数-6 个方向, 各 3 次共计 18 次。 	No.2.1 and 2.2.1 to 2.2.2 shall be satisfied 满足 2.1 项和 2.2.1 至 2.2.2 项。

3.Precaution 注意事项	
3.1 Soldering condition 浸焊条件	
Item 项目	Condition 测试条件
Preheat temperature 预热温度	110°C max (Embilomental temperature of soldering surface of P.C.B) 110°C 以下 (印刷基板焊锡周围的温度)
Preheat time 预热时间	60 sec, max 60 秒以内
Area of flux 助焊剂面积	1/2 max of P.C.B thickness 印刷基板厚度的 1/2 以内
Temperature of solder 焊锡温度	260±5°C max 260±5°C 以下
Times of immersion 浸焊时间	Within 5 sec 5 秒以内
Soldering number 浸焊次数	Within 2 times(But should bring down heat of the first soldering) 2 次以内 (但应把第一次焊锡的温度降下来)
Printed wiring board 印刷基板	Single sided copper-clad laminates 单面铜箔
<p>1) After switches were soldered, please be careful not to clean switches with solvent. 开关浸焊后, 注意不要用溶剂清洗。</p> <p>2) In the case of using soldering iron, soldering conditions shall be 280°C max and 3 sec max. 在使用烙铁的情况下, 焊锡温度应在 280°C 以下、3 秒以内。</p> <p>3) Right after switches were soldered; please be careful not to load on the knobs of switches. 浸焊后, 注意不要在手柄顶部施加负荷。</p> <p>3.2 Design instructions (设计中应注意事项)</p> <p>1) Follow recommended P.C.B piercing plan in the outside drawing page. 印刷基板的安装孔尺寸参见产品图。</p> <p>3.3 Note (注意点)</p> <p>1) Please be cautious not to give excessive static load or shock to switches. 注意不要施加超过负荷的压力或晃动开关。</p> <p>2) Please be careful not to pile up P.C.B after switches were soldered. 开关焊接以后, 印刷基板注意不要叠放。</p> <p>3) Preservation under high temperature and high humidity or corrosive gas should be avoided especially. When you need to preserve for a long Period, do not open the carton. 保管时尤其应注意避开高湿高温和有腐蚀性气体的环境, 如需长时间保存, 请不要打开包装箱。</p>	

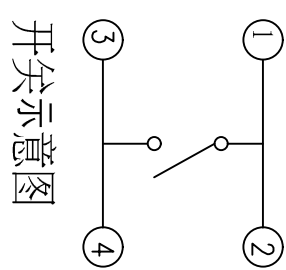
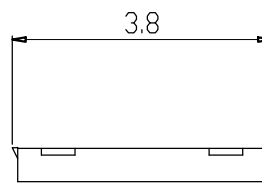
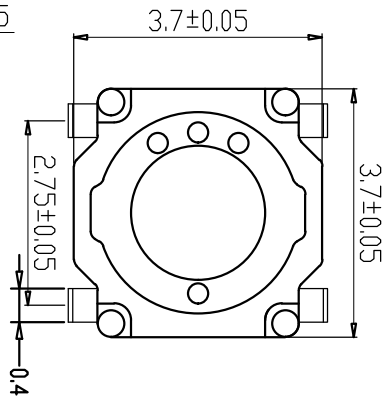

开关示意图

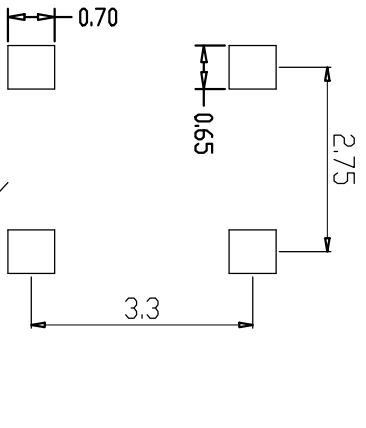
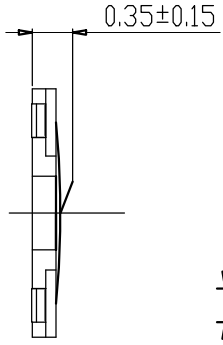

SPECIFICATIONS

1. Operating temperature range: -30°C to 85°C
2. Rating: DC12V 50mA
3. Insulation resistance: $100\text{M}\Omega$ min 100V DC
4. Dielectric strength: 250V AC for 1min.
5. Contact resistance: $100\text{m}\Omega$ Max
6. Operating force: $250\pm 50\text{gf}$
7. Travel: $0.15\pm 0.05\text{mm}$
8. Operating life: 250gf 80,000 Cycle

4	膜	聚酞亚胺	1	黄色
3	弹片	SUS301	1	镀银
2	底座	LCP	1	黑色
1	端子	磷铜C5191	1	镀银
编号	部件名称	材料名称	数量	备注

YIBST 深圳市亿利百斯特电子有限公司
 亿利百斯特 Shenzhen Elybest Electronics Co., Ltd

单 位	mm	制 图	设计	审 核	校 准	批 准	日 期	核 准	修 改	标 记
UNIT	mm	DRAW	DESIGN	CHECKED	STANDARD	APPROVE	DATE	APPROVE	REVISE	MARK
	裴滔		吴新生	简小波						EON 编号/变更内容 EON NO./DEFINITION
	杨建飞			潘传彬						

一般公差		名称	型号	图号	角法
GENERAL TOLERANCE	ANGLES	TITLE	MODEL	DWG. NO.	PROJ.
X \pm 0.5	X \pm 5'				
.XX \pm 0.2					
.XXX \pm 0.1	X \pm 2'				
材 质					
MATERIAL					
重 量					
WT.					
表面积					
SA.					

轻触开关	产品编码	张数
MODEL	MODEL NO	SHEET
EL-3302B		A0
比例	版本	第 页 共 页
SCALE	REV.	
10 : 1		